

## BAD PRACTICE 不良作業方式

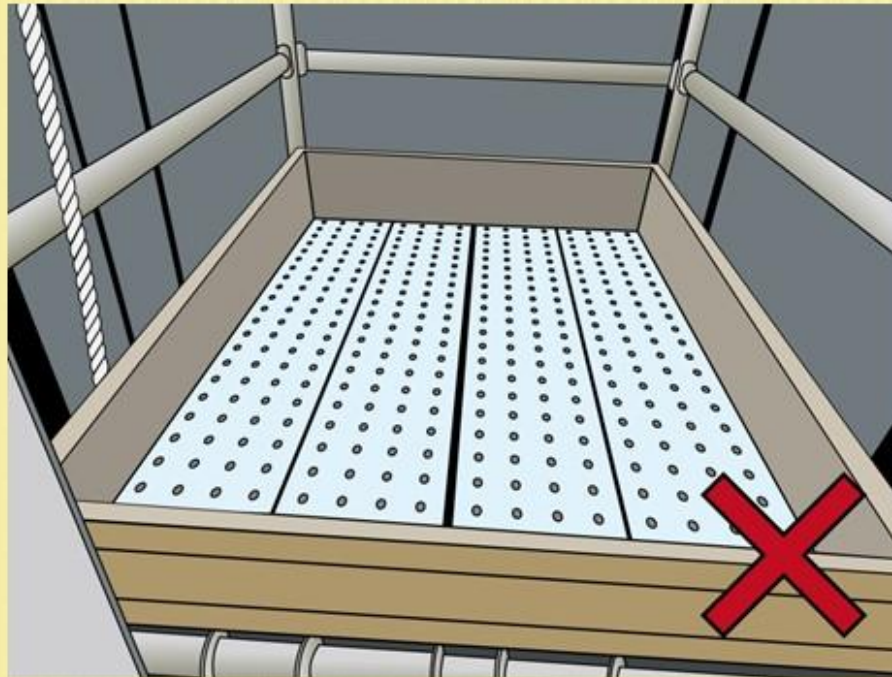

**No stairs / ladders were observed as the safe means of access and egress to the lift pit.**

沒有提供安全的樓梯/梯子進出升降機槽底。

## BAD PRACTICE 不良作業方式

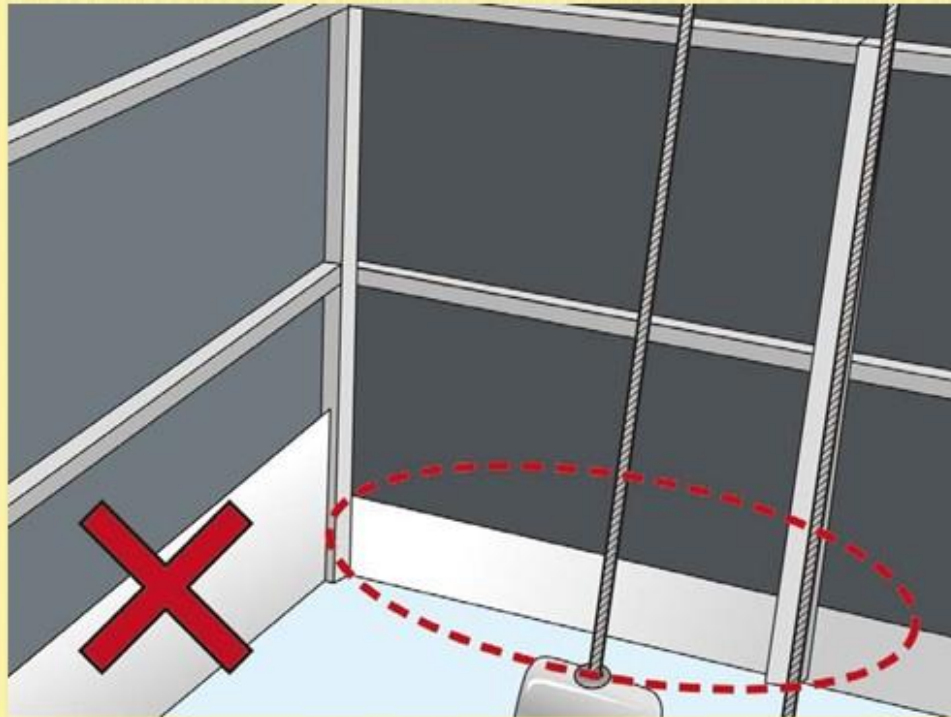

A portion of toe-board was found not up to the required 200MM height

部分踢腳板發現不夠所需的200MM高度。

## BAD PRACTICE 不良作業方式

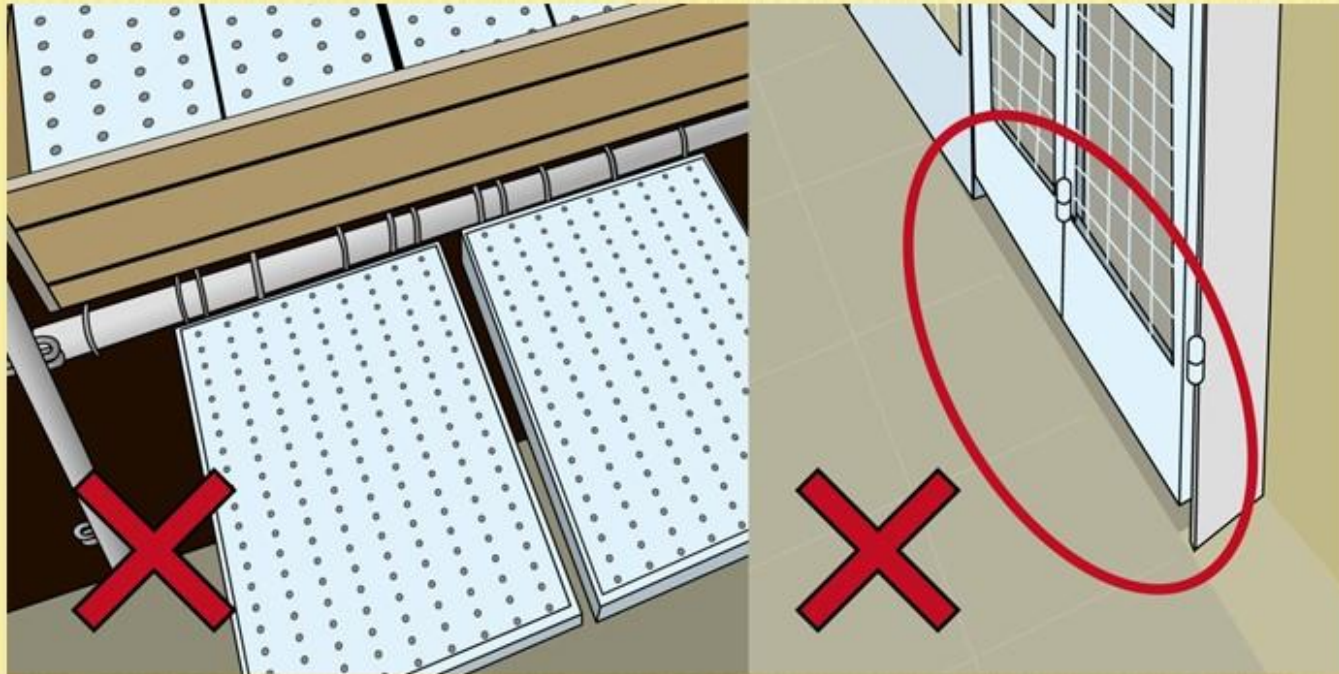

**Gaps were found at the access and the toeboard of the gate - room to improvement**

通道及踢腳板上發現空隙



## BAD PRACTICE 不良作業方式



Dangerous edge was not guarded and toeboard was found missing 危險的邊緣未有保護好及沒有踢腳板

## BAD PRACTICE 不良作業方式



Wire sling was found without colour code 吊索被發現沒有噴上顏色代碼。



Independent life line provided at lift shaft. However, the loading capacity should be further checked and confirmed to meet the COP requirement 雖然升降機槽已提供獨立救生繩，但承載能力應進一步檢查和確認。

## BAD PRACTICE 不良作業方式

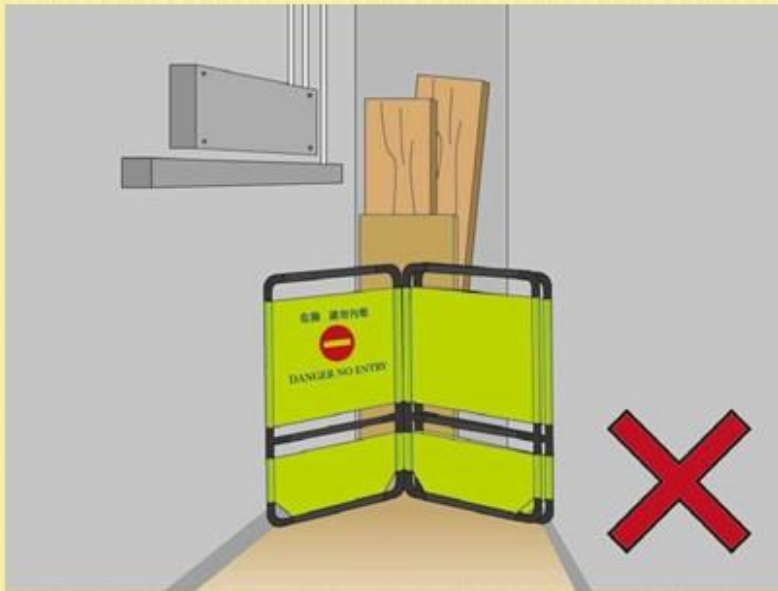

Materials should be cleared off  
in the public area 物料不應該  
堆放在公共區域

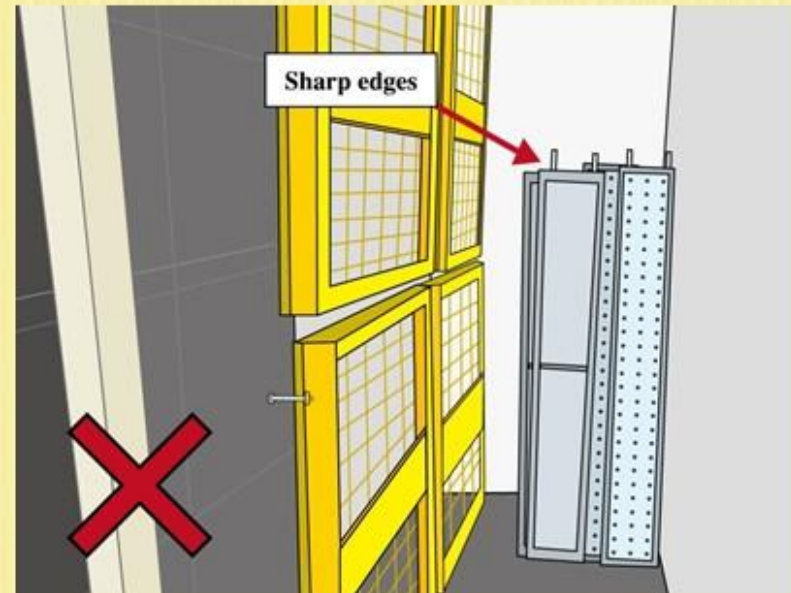

Stored materials were not fixed  
properly.  
不安全的物料堆放



## BAD PRACTICE 不良作業方式

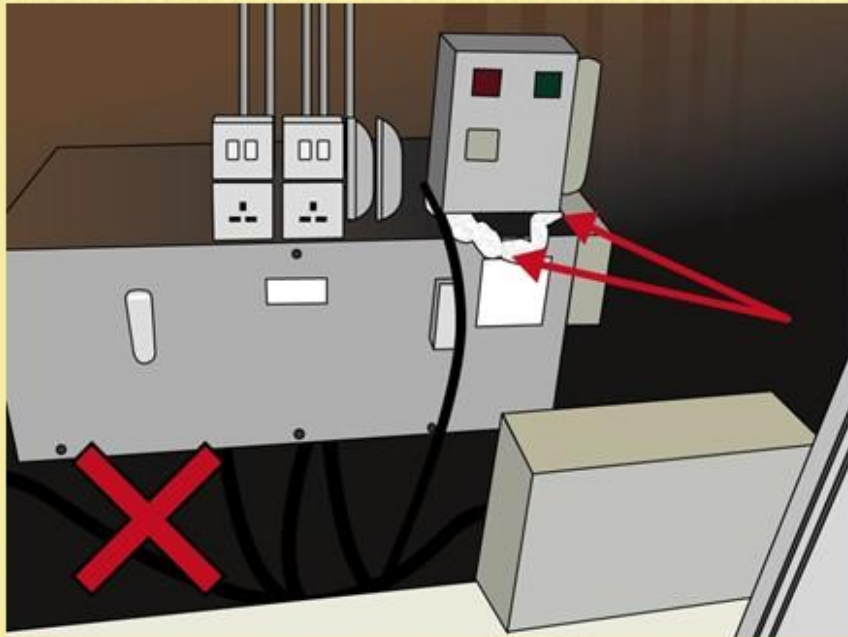

Improper waste disposal on top of the lift car was observed 電梯轎廂的頂部有廢物堆放。

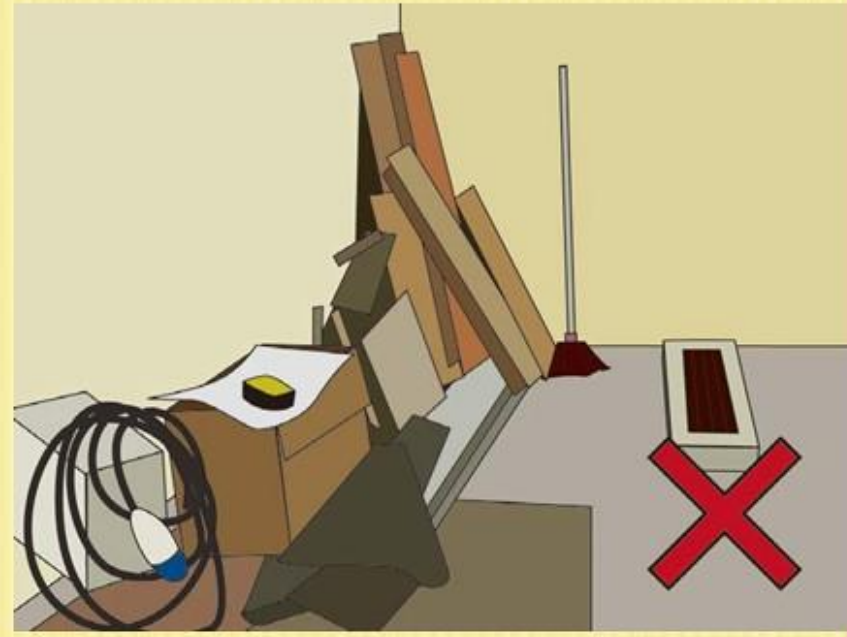

Construction materials should be stored properly in the machine room 在機房施工材料應妥善保存。

## BAD PRACTICE 不良作業方式

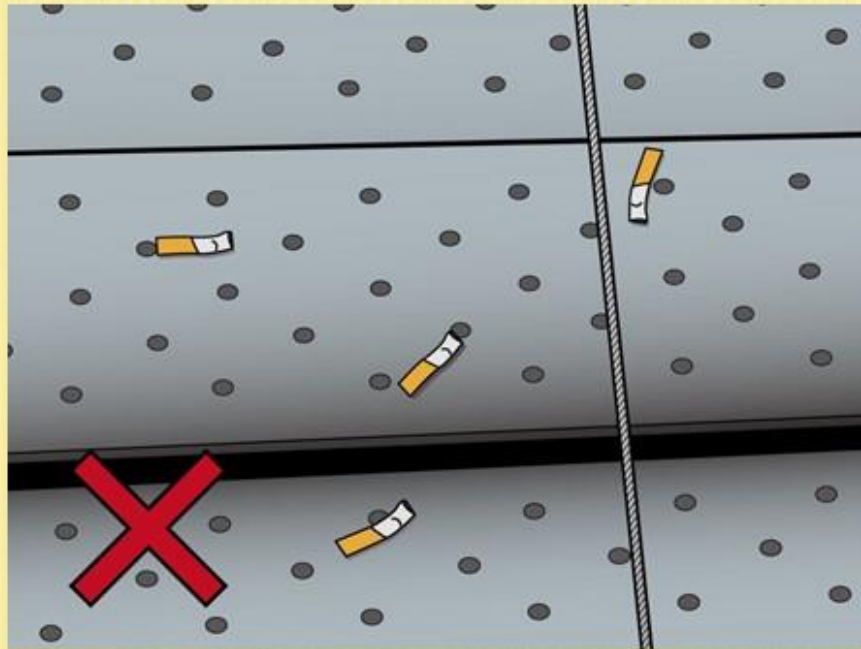

Cigarette ends in workplace  
在工作場所棄置煙蒂



Sharp edges of H-beams in lift machine  
room should be adequately protected.  
在電梯機房的鋒利的邊緣應得到充分保護。



## BAD PRACTICE 不良作業方式



**The bonding line should be maintained in a good condition** 接合線應保持在良好狀態

## BAD PRACTICE 不良作業方式

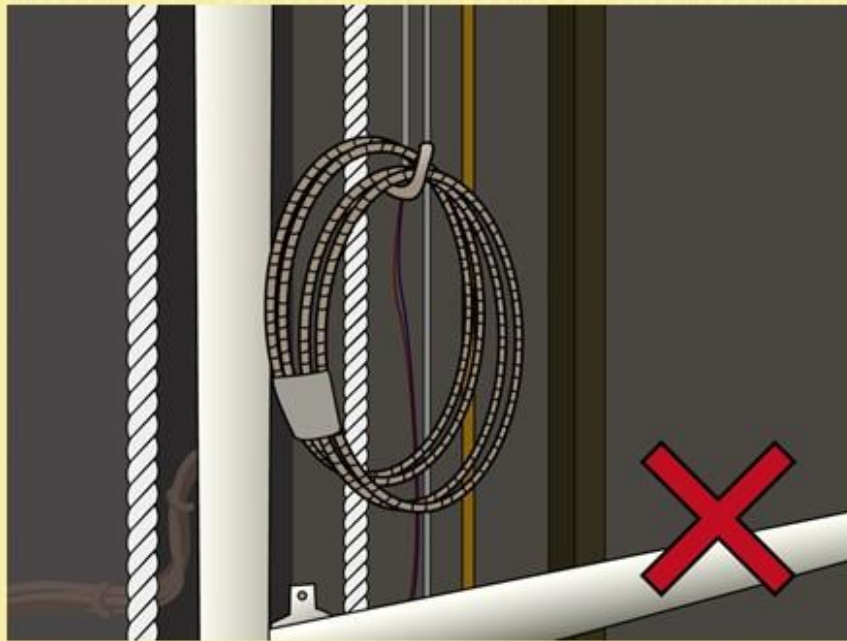

Lifting gear inside the lift shaft did not have proper colour code

升降機槽內的起重裝置欠缺顏色代碼

## BAD PRACTICE 不良作業方式

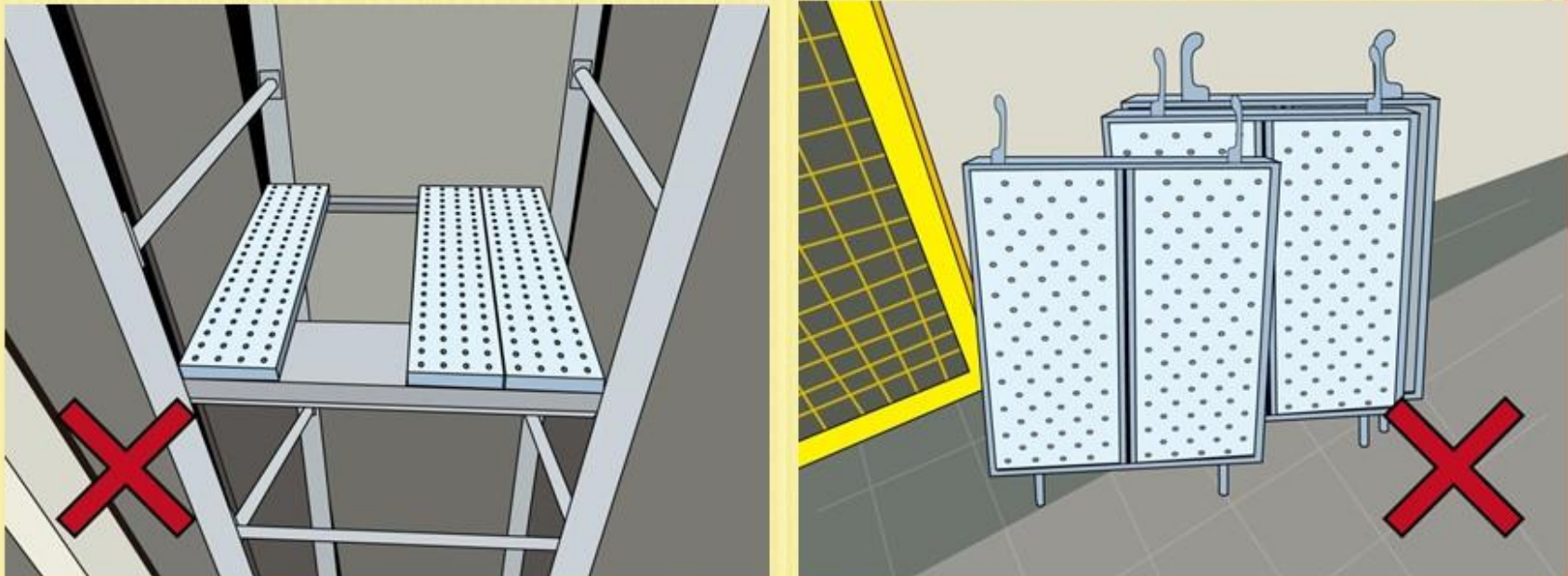

Working platform of the metal scaffold inside the lift shaft was not provided with full set of planking / toe-boards / guard-rails 未有裝好地台板/ 踢腳板/ 安全圍欄的工作平台



## BAD PRACTICE 不良作業方式

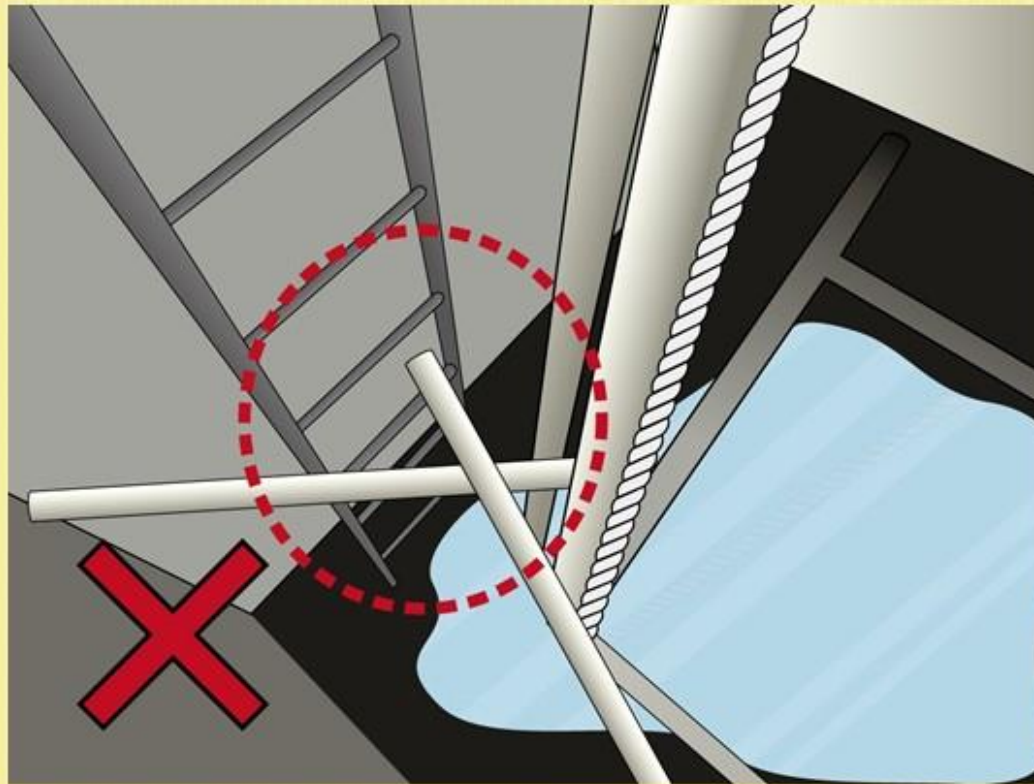

Cat-ladder was obstructed by the tieback. Stagnant water was observed in the lift pit

爬梯(貓梯)被繫桿阻塞, 升降機槽底部有積水

## BAD PRACTICE 不良作業方式



Substandard Lanyard of Safety Harness  
防墮裝置(安全帶防墮扣)未有保養好

## BAD PRACTICE 不良作業方式

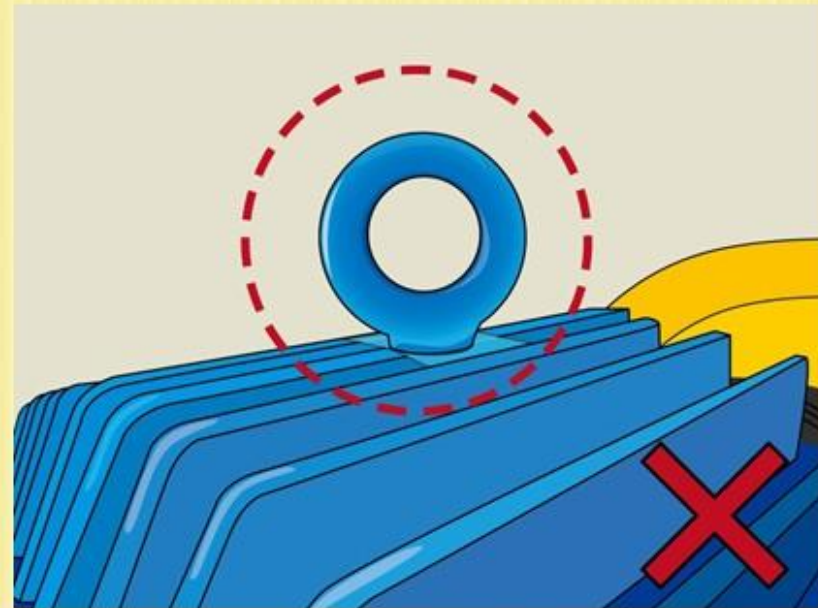
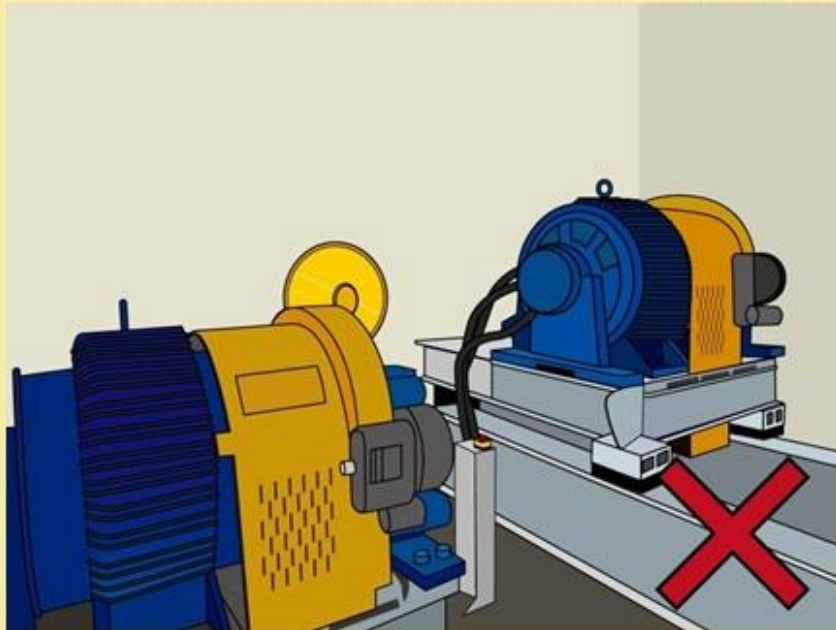

Unable to present the test certificate of the lifting eye during the audit verification on site 未能出示防墮裝置錨固點的檢驗證書



## BAD PRACTICE 不良作業方式



Poor Housekeeping at the access  
升降機槽出入口欠妥善整理

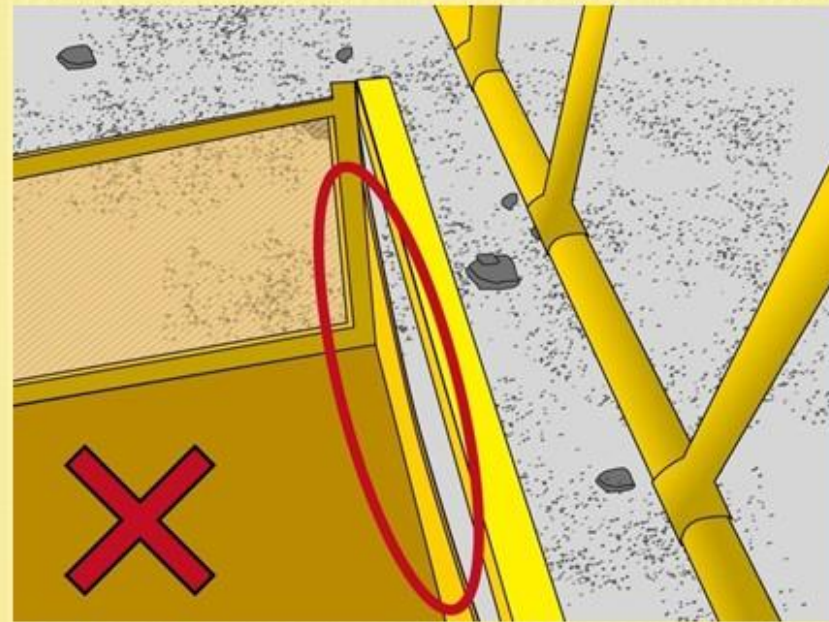

Improper Protection of Sharp Material  
鋒利物料保護不當

## BAD PRACTICE 不良作業方式

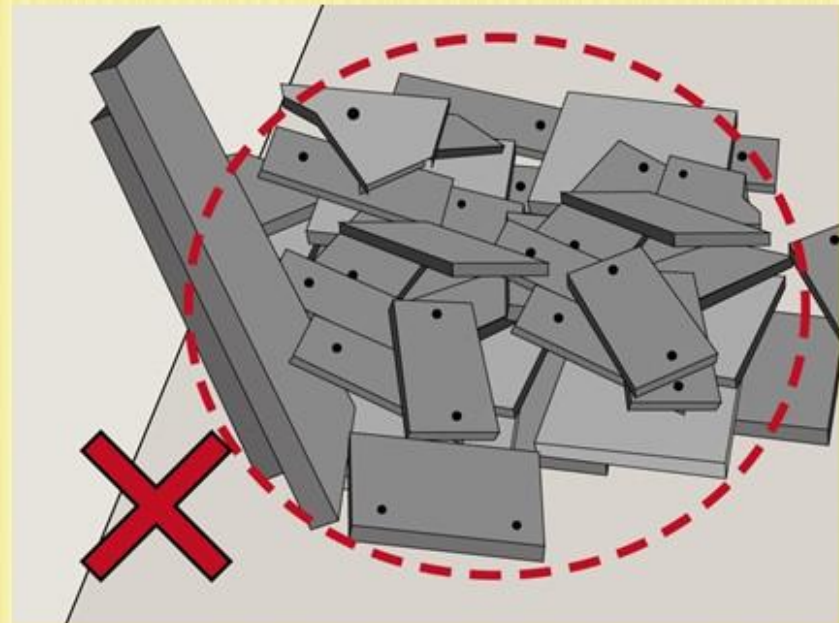
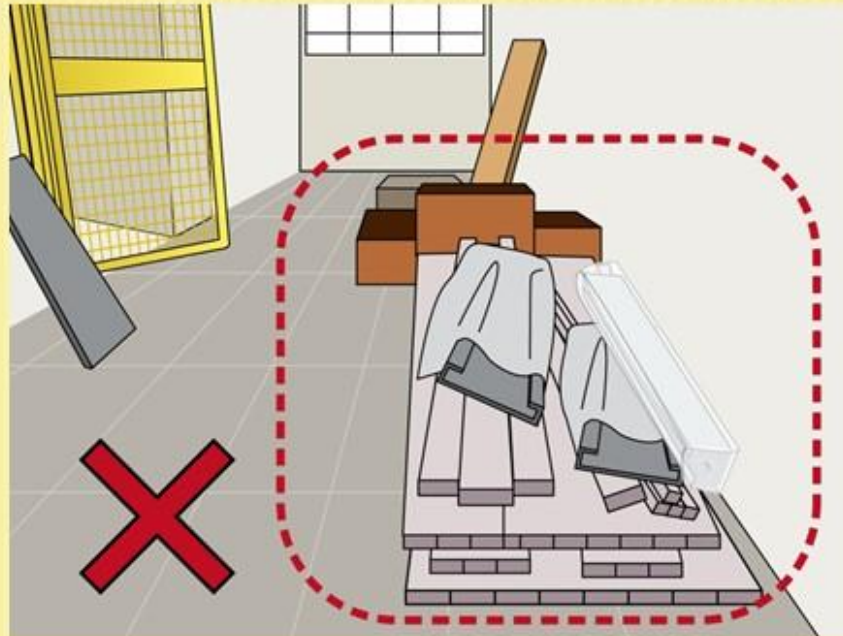

Workplace was not Maintained in Good Condition

- 1) add barrier to separate the storage area
- 2) container should be provided to store small objects

工地設施欠妥善整理

- 1)使用圍欄分隔物料儲存區域
- 2)提供存箱子儲較小的物料



## BAD PRACTICE 不良作業方式



In-running roller have gap with proper protection 運行中滾軸有縫隙，保護不當

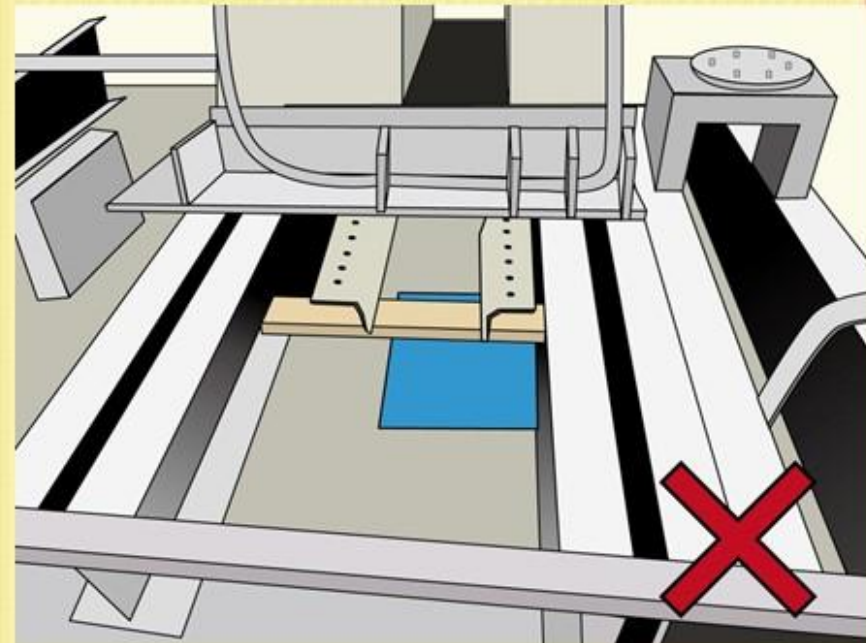

The small openings should be protected by the timber plates instead of the poly-foam

開口保護不當，應用較堅固料蓋好



## BAD PRACTICE 不良作業方式

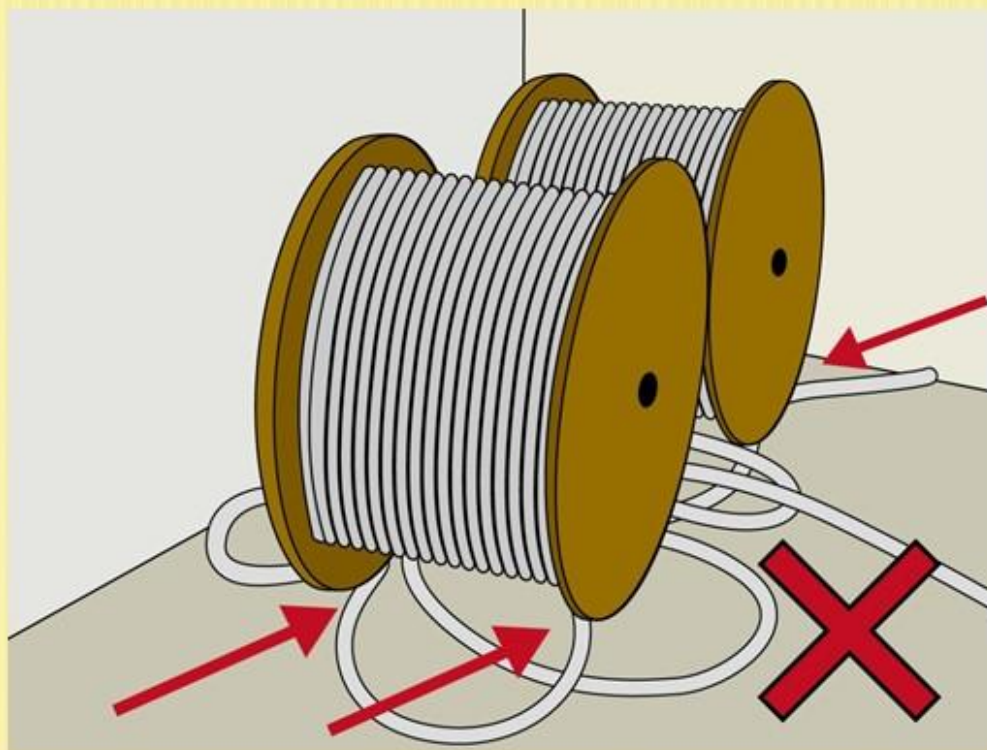

Improper Wedge of Cable Drums  
電纜滾筒欠妥善整理

## BAD PRACTICE 不良作業方式



Improper Guarding on Electrical Winch  
電器絞盤保護不當

## BAD PRACTICE

- Working platform was not provided together with full set of planking / toe-boards / guard-rails in the metal scaffold inside the lift shaft
- 未有裝好工作平台的地台板/ 踢腳板/ 安全圍欄

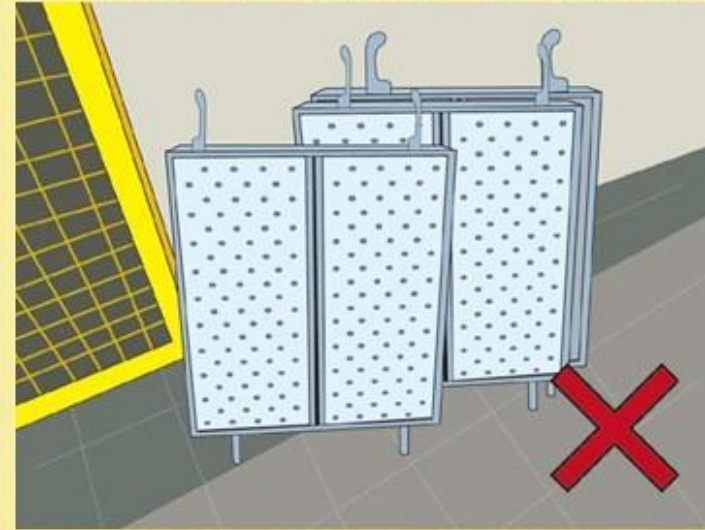
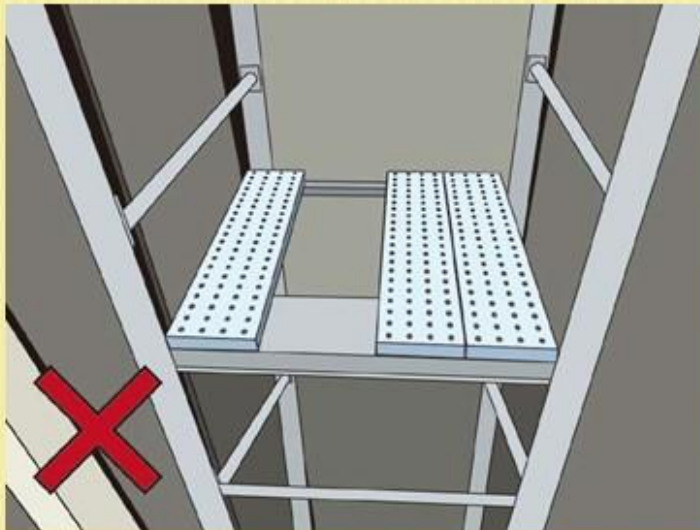



## BAD PRACTICE

- Cat-ladder was obstructed by the tieback, stagnant water was observed in the lift pit
- 爬梯(貓梯)被回接管阻塞, 電梯槽底部有積水



## BAD PRACTICE

- Improper working platform
- 不當工作台



## BAD PRACTICE

- Poor housekeeping at the access
- 升降機槽出入口欠妥善整理





## BAD PRACTICE

- Inadequate protective guard to the in-running roller
- 運行中滾軸有縫隙，保護不當



## BAD PRACTICE

- Water contained in lift shaft
- 升降機槽內有積水

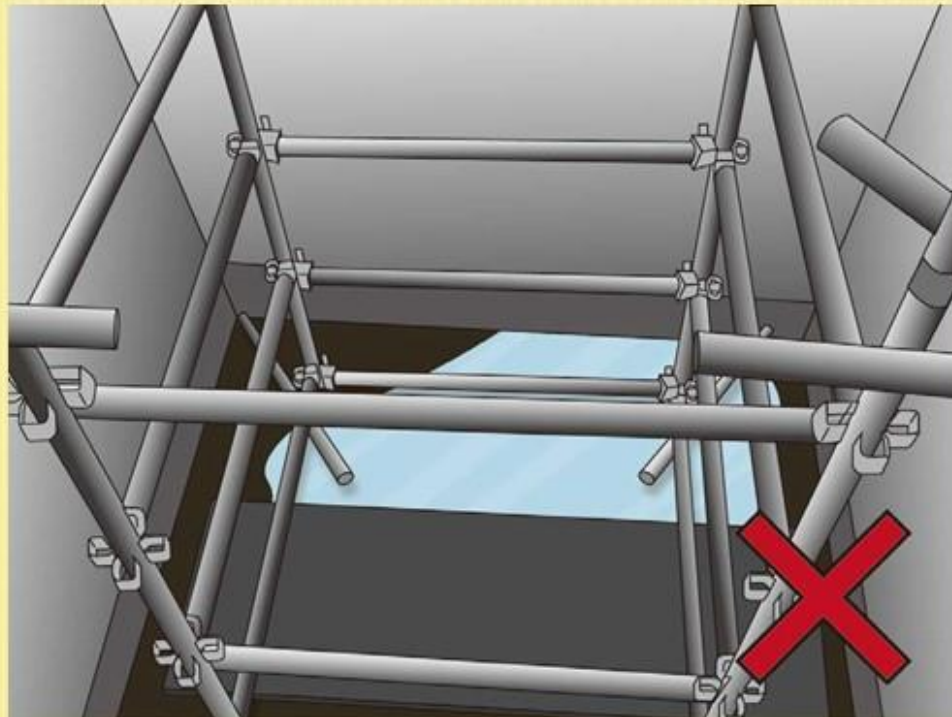

## BAD PRACTICE

- Damaged electrical connector
- 損壞的接頭





## BAD PRACTICE

- Unsafe access to working platform
- 不安全進出口

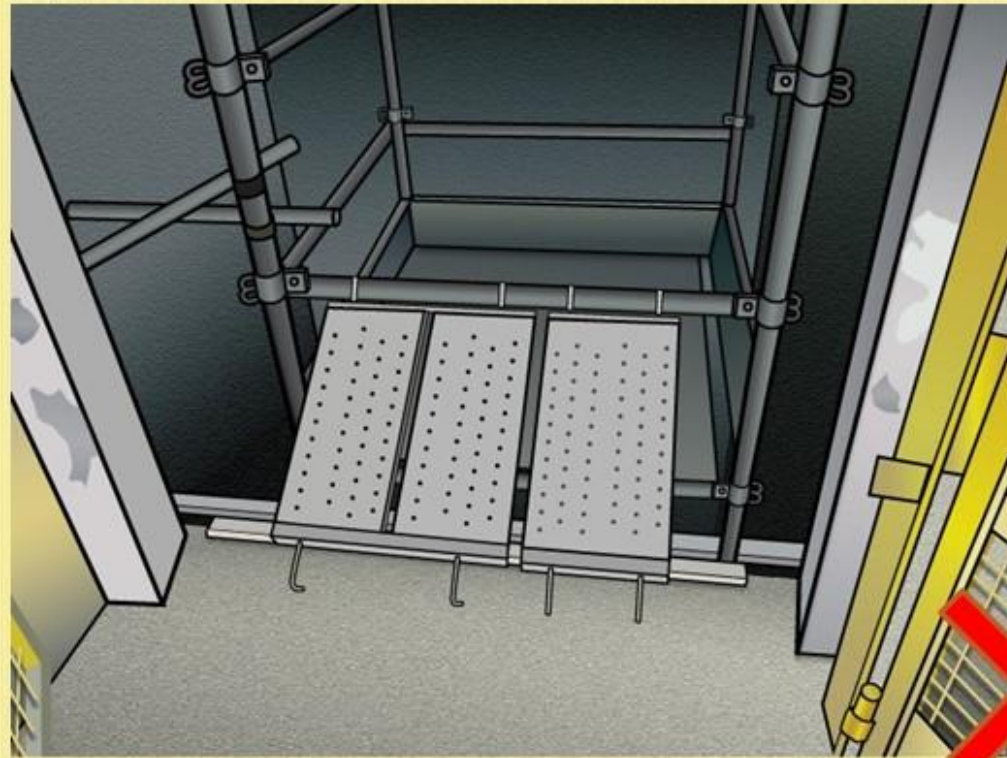

## BAD PRACTICE

- Floor opening was not protected
- 地洞沒有覆蓋



## BAD PRACTICE

- Materials stacked at high level
- 物料存放於高處

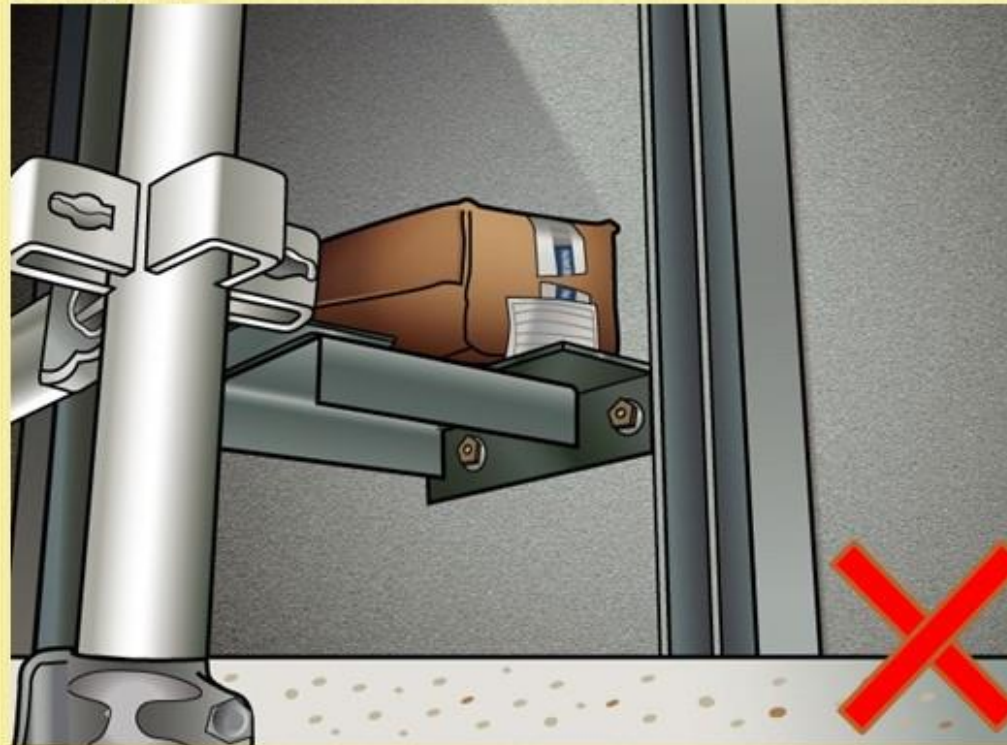



## BAD PRACTICE 不良作業方式

- Absence of mid-rail in the metal scaffold
- 金屬棚架沒有中圍欄



## BAD PRACTICE 不良作業方式

- Absence of top guard-rail in the metal scaffold
- 金屬棚架沒有高圍欄



## BAD PRACTICE 不良作業方式

- Hanging block was installed on the metal scaffold
- 安裝鏈滑車在金屬棚架

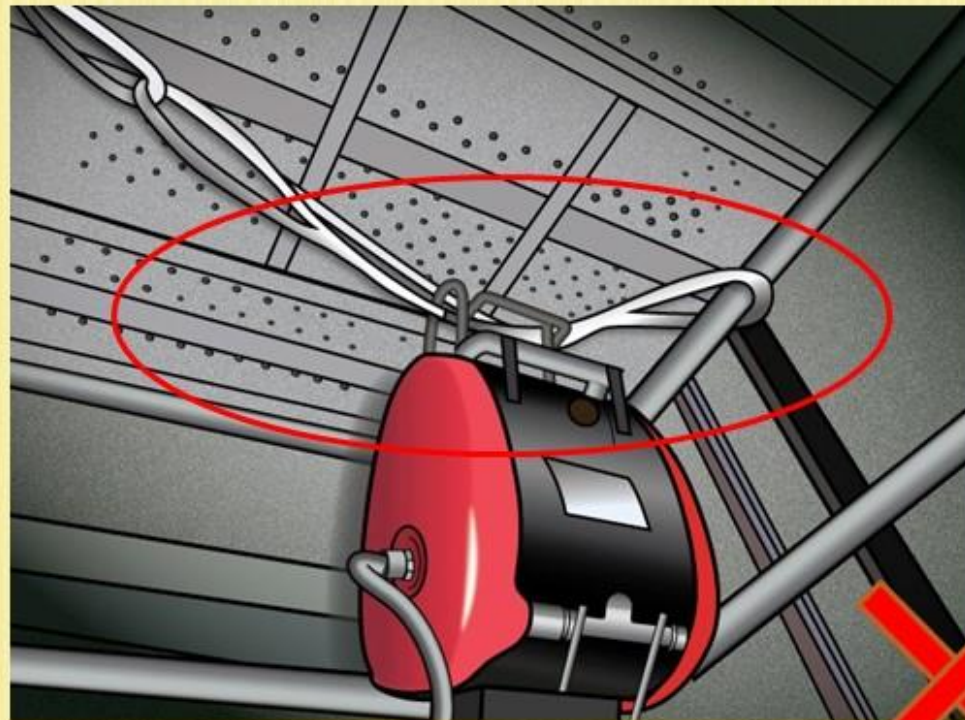



## BAD PRACTICE不良作業方式

- Improper guarding for electric winch
- 電動絞機的危險部份沒有完全隔開

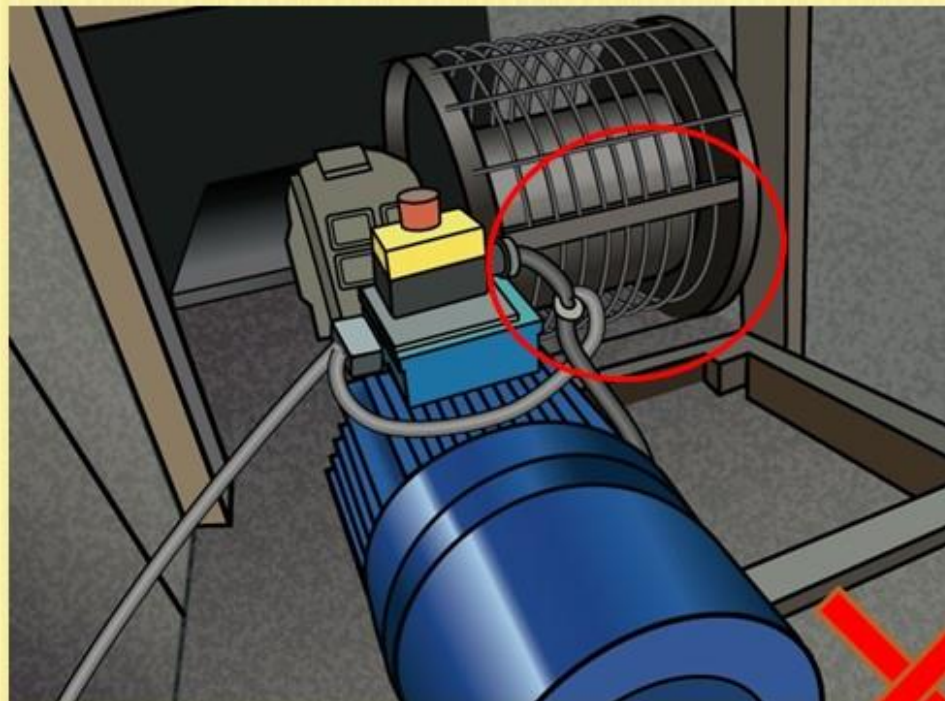

## BAD PRACTICE 不良作業方式

- Material left at high level
- 物料留高處

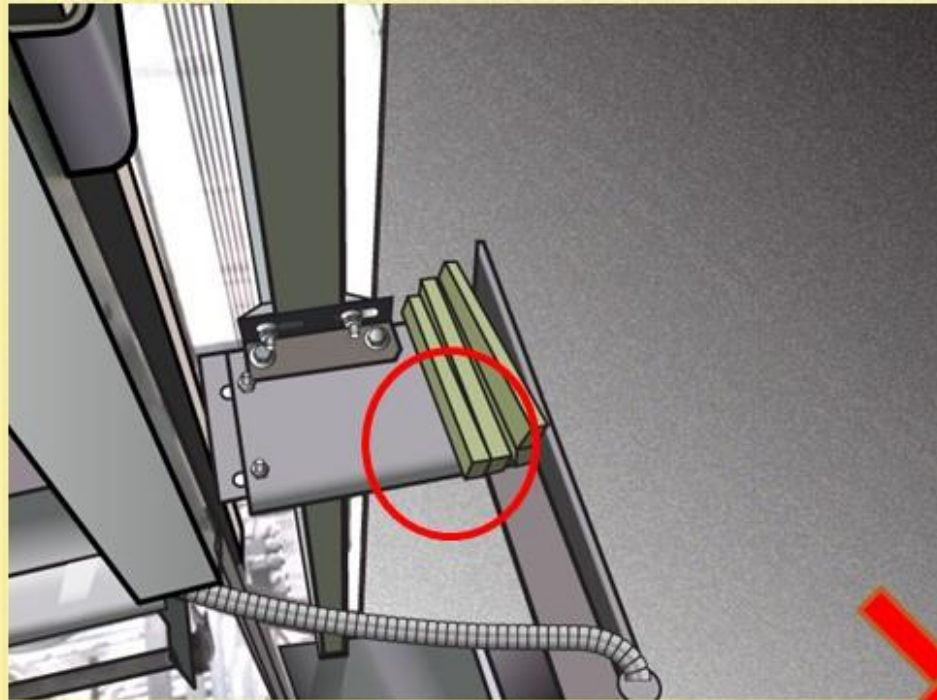

## BAD PRACTICE 不良作業方式

- The access was obstructed by the accumulated rubbish
- 通道被堆積的垃圾阻塞





## BAD PRACTICE 不良作業方式

- Floor edge without fencing in lift shaft
- 未有在臨邊位置安裝圍欄



## BAD PRACTICE 不良作業方式

- Electric cable laid on ground floor and invalid cable connector used at work
- 電線沒有掛高及使用不恰當的電纜連接器

